

M10-82716-14
Issue A March 1997

**Miniature Grips
for
Low-Force Testing**

Operator's Guide



PROPRIETARY RIGHTS NOTICE

This document and the information that it contains are the property of Instron Corporation. Rights to duplicate or otherwise copy this document and rights to disclose the document and the information that it contains to others and the right to use the information contained therein may be acquired only by written permission signed by a duly authorized officer of Instron Corporation.

© Copyright 1997 Instron Corporation

Amendment Incorporation Record			
Amendment No.	Brief Description of Content	ECR No.	Person Incorporating Amendment
1			
2			
3			
4			
5			
6			
7			
8			
9			
10			

Amendment Incorporation Record			
Amendment No.	Brief Description Of Content	ECR No.	Person Incorporating Amendment
11			
12			
13			
14			
15			
Revision Record			
Revision			ECR No.

General Safety Precautions

Materials testing systems are potentially hazardous.

Materials testing involves inherent hazards from high forces, rapid motions and stored energy. You must be aware of all moving and operating components which are potentially hazardous, particularly the actuator in a servo-hydraulic testing system or the moving crosshead in an electromechanical testing system.

Whenever you consider that safety is compromised, press the Emergency Stop button to stop the test and isolate the testing system from hydraulic or electrical power.

Carefully read all relevant manuals and observe all Warnings and Cautions. The word Warning is used where a hazard may lead to injury or death. The word Caution is used where a hazard may lead to damage to equipment or to loss of data.

Ensure that the test set-up and the actual test you will be using on materials, assemblies or structures constitutes no hazard to yourself or others. Make full use of all mechanical and electronic limits features. These are supplied for your safety to enable you to prevent movement of the actuator piston or the moving crosshead beyond desired regions of operation.

The following pages detail various general warnings that you must heed at all times while using materials testing equipment. You will find more specific Warnings and Cautions in the text whenever a potential hazard exists.

Your best safety precautions are to gain a thorough understanding of the equipment by reading your instruction manuals and to always use good judgment.

Warning

Disconnect the electrical power supply before removing the covers to electrical equipment.

Disconnect equipment from the electrical power supply before removing any electrical safety covers or replacing fuses. Do not reconnect the power source while the covers are removed. Refit covers as soon as possible.

Disconnect power supplies before removing the covers to rotating machinery.

Disconnect equipment from all power supplies before removing any cover which gives access to rotating machinery. Do not reconnect any power supply while the covers are removed unless you are specifically instructed to do so in the manual. If the equipment needs to be operated to perform maintenance tasks with the covers removed, ensure that all loose clothing, long hair, etc. is tied back. Refit covers as soon as possible.

Shut down the hydraulic power supply and discharge hydraulic pressure before disconnection of any hydraulic fluid coupling.

Do not disconnect any hydraulic coupling without first shutting down the hydraulic power supply and discharging stored pressure to zero. Tie down or otherwise secure all pressurized hoses to prevent movement during system operation and to prevent the hose from whipping about in the event of a rupture.

Warning

Shut off the supply of compressed gas and discharge residual gas pressure before you disconnect any compressed gas coupling.

Do not release gas connections without first disconnecting the gas supply and discharging any residual pressure to zero.

Use protective shields or screens if any possibility exists of a hazard from the failure of a specimen, assembly or structure under test.

Use protective shields whenever a risk of injury to operators and observers exists from the failure of a test specimen, assembly or structure, particularly where explosive disintegration may occur. Due to the wide range of specimen materials, assemblies or structures that may be tested, any hazard resulting from the failure of a test specimen, assembly or structure is entirely the responsibility of the owner and the user of the equipment.

Protect electrical cables from damage and inadvertent disconnection.

The loss of controlling and feedback signals that can result from a disconnected or damaged cable causes an open loop condition which may drive the actuator or crosshead rapidly to its extremes of motion. Protect all electrical cables, particularly transducer cables, from damage. Never route cables across the floor without protection, nor suspend cables overhead under excessive strain. Use padding to avoid chafing where cables are routed around corners or through wall openings.

Warning

Wear protective clothing when handling equipment at extremes of temperature.

Materials testing is often carried out at non-ambient temperatures using ovens, furnaces or cryogenic chambers. Extreme temperature means an operating temperature exceeding 60 °C (140 °F) or below 0 °C (32 °F). You must use protective clothing, such as gloves, when handling equipment at these temperatures. Display a warning notice concerning low or high temperature operation whenever temperature control equipment is in use. You should note that the hazard from extreme temperature can extend beyond the immediate area of the test.

Take care when installing or removing a specimen, assembly or structure.

Installation or removal of a specimen, assembly or structure involves working inside the hazard area between the grips or fixtures. Keep clear of the jaws of a grip or fixture at all times. Keep clear of the hazard area between the grips or fixtures during actuator or crosshead movement. Ensure that all actuator or crosshead movements necessary for installation or removal are slow and, where possible, at a low force setting.

Warning

Do not place a testing system off-line from computer control without first ensuring that no actuator or crosshead movement will occur upon transfer to manual control.

The actuator or crosshead will immediately respond to manual control settings when the system is placed off-line from computer control. Before transferring to manual control, make sure that the control settings are such that unexpected actuator or crosshead movement cannot occur.

Keep clear of the operating envelope of a robotic device unless the device is de-activated.

The robot in an automated testing system presents a hazard because its movements are hard to predict. The robot can go instantly from a waiting state to high speed operation in several axes of motion. During system operation, keep away from the operating envelope of the robot. Deactivate the robot before entering the envelope for any purpose, such as reloading the specimen magazine.

Table of Contents

Chapter	Page
1 Introduction	
Overview	1-1
Purpose	1-2
About this Manual	1-3
Wedge Grips	1-5
Screw Grips	1-7
Chuck Grips	1-9
Lever-Action Fiber Grips	1-11
2 Specifications	
Overview	2-1
Wedge Grips	2-2
Specifications	2-2
Dimensions	2-2
Screw Grips	2-4
Specifications	2-4
Dimensions	2-4
Chuck Grips	2-6
Specifications	2-6
Dimensions	2-6
Lever-Action Fiber Grips	2-8

Table of Contents (continued)

Chapter	Page
2 Specifications (continued)	
Specifications	2-8
Dimensions	2-8
3 Installation	
Overview	3-1
General	3-2
Grip Installation	3-3
Fiber Grips	3-4
Converting from Vertical to Horizontal Mounting	3-4
4 Operation	
Overview	4-1
General	4-2
Wedge Grips	4-3
Installing Grip Faces	4-3
Loading Specimens	4-4
Screw Grips	4-7
Installing Grip Faces	4-7
Loading Specimens	4-9
Chuck Grips	4-11

Table of Contents (continued)

Chapter	Page
4 Operation (continued)	
Lever Action Fiber Grips	4-13
Loading Specimens	4-13
Adjusting Gripping Force	4-13
5 Maintenance	
Overview	5-1
General	5-2
Lubricating Wedge Grips	5-3
6 Illustrated Parts	
Overview	6-1
General	6-2
Wedge Grips Parts List	6-4
Screw Grips Parts List	6-6
Chuck Grips Parts List	6-8
Lever Action Fiber Grips Parts List	6-10

List of Illustrations

Figure	Page
1-1. Wedge Grips	1-4
1-2. Screw Grips	1-6
1-3. Chuck Grips	1-8
1-4. Lever-Action Fiber Grips	1-10
2-1. Wedge Grip Dimensions	2-3
2-2. Screw Grips Dimensions	2-5
2-3. Chuck Grips Dimensions	2-7
2-4. Lever-Action Fiber Grips Dimensions	2-9
3-1. Vertical to Horizontal Mounting Conversion	3-6
3-2. Mounting the Grip	3-7
3-3. Adjusting Grip Position on the Post	3-7
4-1. Wedge Grip Operation	4-5
4-2. Screw Grip Operation	4-8
4-3. Lever Action Fiber Grips Operation	4-14
6-1. Wedge Grips Parts Breakdown	6-4
6-2. Screw Grips Parts Breakdown	6-6
6-3. Chuck Grips Parts Breakdown	6-8

List of Illustrations (continued)

Figure		Page
6-4.	Lever Action Fiber Grips Parts Breakdown	6-10
6-5.	Horizontal Mounting Parts	6-12

List of Tables

6-1.	Wedge Grips Parts List	6-5
6-2.	Screw Grips Parts List	6-7
6-3.	Chuck Grips Parts List	6-9
6-4.	Lever Action Fiber Grips Parts List	6-11

Chapter 1 Introduction

Overview

- Purpose.....Page 1-2
- About this Manual.....Page 1-3
- Wedge Grips.....Page 1-5
- Screw Grips.....Page 1-7
- Chuck GripsPage 1-9
- Lever-Action Fiber Grips.....Page 1-11

This chapter describes several types of miniature grips designed for lightly loaded materials testing. Included is a description of the grips, their specifications, installation, operation, maintenance, and, in most cases, a parts breakdown.

Purpose

The four types of miniature grips covered by this manual are designed for use with Instron's single column load frames. Their small size and low force ratings make them ideal for this application, but they are equally useful on Instron's regular line of tensile testing instruments.

This manual covers four types of grips: a set of mechanical action wedge grips, manually operated screw grips, a set of chuck grips similar to the chuck on an electric drill, and a set of pincer-action fiber grips.

To complete the collection of miniature grips, in addition to the grips covered here, certain models of pneumatic wedge grips, cord and yarn grips, and fiber grips from the standard series of grips of these types can also be used on the single-screw load frame. Since manuals already exist for these grips, they are covered there instead of in this manual.

About this Manual

The four types of grips described are covered throughout this manual. The manual is divided into chapters covering description, specifications, installation, operation, maintenance, and parts breakdown. The chapters are subdivided into information about each type of grip.

Throughout the chapters, the order of presenting the grips – wedge, screw, chuck, and fiber – the same, so that you will find navigating through the manual easier, and can easily find the information about the particular grip you are working with. Each type of grip has its own major heading within each chapter.

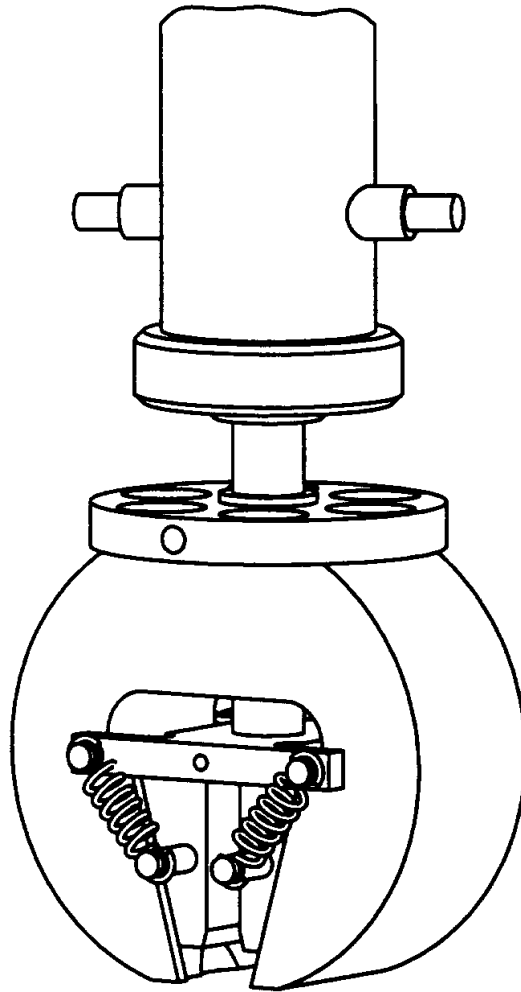

Figure 1-1. Wedge Grips

Wedge Grips

The Model 2716-016 and 017 wedge grips are mechanical wedge-action grips. The capacity of the 016 grip is 1kN (220 lb) and the capacity of the 017 grip is 2 kN (440 lb).

In operation, the jaw faces that grip the test specimen are pressed together by movement of the grip body. The jaw faces are located in a tapered opening in the grip body, and as an operating ring (or thumbwheel) is turned, the grip body is raised or lowered while the jaws remain stationary (see Figure 1-1). This action forces the jaw faces together or apart. The amount of gripping force applied to the specimen is controlled by how hard the operating ring is turned. Because the jaw faces do not move, minimal preload is applied to the specimen while the grips are tightened.

The jaw faces are interchangeable and have serrated faces to accommodate flat specimens of material, such as thin sheet metal.

The 1 kN grip is made of aluminum, the 2 kN grip is made of stainless steel.

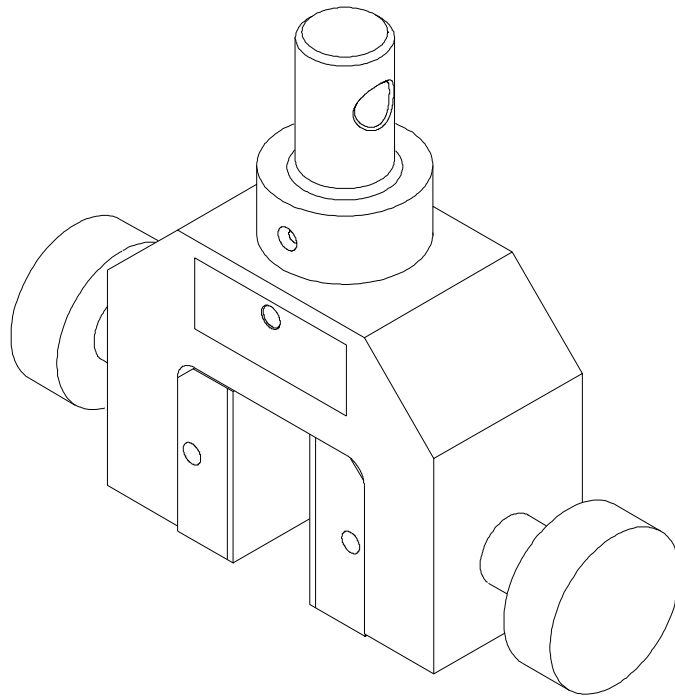

Figure 1-2. Screw Grips

Screw Grips

The Model 2710-004 side-acting screw grips are somewhat similar to the Wedge Grips, except that the gripping force is supplied by two tightening knobs on the sides of the grips (see Figure 1-2). These tightening knobs are hand-operated, and the jaw faces are self-aligning, though not self-centering. The clamping force is adjustable by how hard the knobs are tightened.

There are several types of interchangeable jaw faces to accommodate different types of specimens:

- Smooth Face – This face is used for flat specimens, such as paper and thin films.
- Serrated Face – This face is used for flat specimens of harder material, such as thin sheet metal.
- Rubber Coated Face – This face is used for flat specimens that may be slippery, such as plastic films.
- Line Contact Face – This face has a rubber coated face on one side, and a horizontal, semi-circular rib on the other. This face is used for fibers and fine wire.

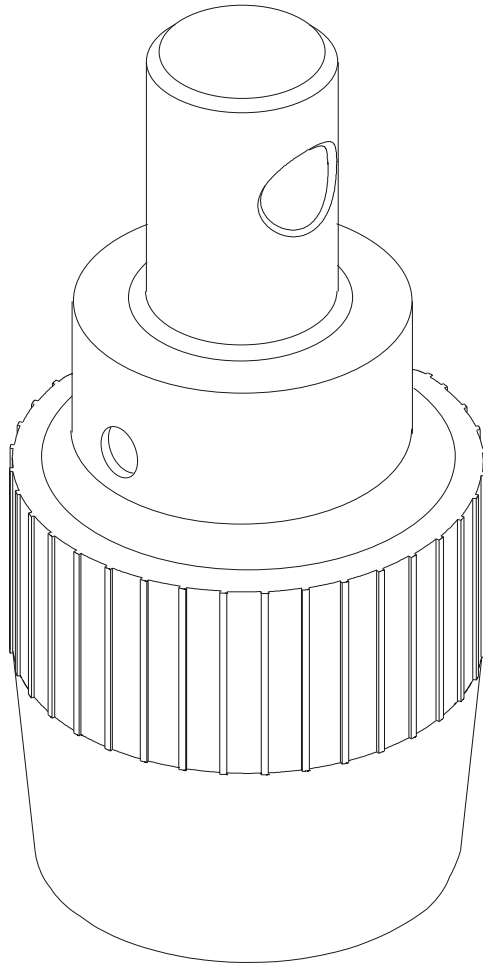

Figure 1-3. Chuck Grips

Chuck Grips

The Model 2830-001 chuck grips are lightweight three-jaw keyless chucks, similar to the type used in electric drills, that are adapted for use in Instron Type 0 grip couplings (see Figure 1-3). They have a soft plastic coating for easy tightening. You adjust the gripping force on the specimen by varying the amount of torque applied to the chuck.

The chuck grips are suitable only for round and hexagonal specimens, and the chuck jaws are not interchangeable.

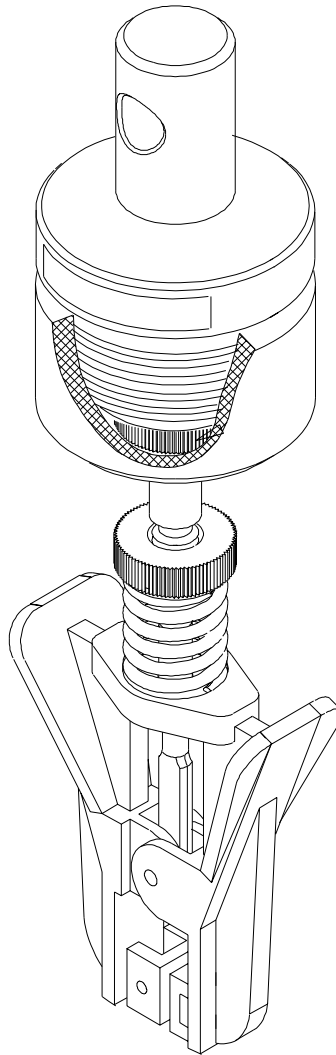

Figure 1-4. *Lever-Action Fiber Grips*

Lever-Action Fiber Grips

The Model 2711-006 lever-action fiber grips have two spring-loaded levers to provide clamping force on a test specimen. This action is a pincer action, and is suitable for single fiber and very fine wire specimens (see Figure 1-4). You adjust the clamping force by changing the compression on the spring with a thumbwheel.

The grips can be mounted in either a vertical or horizontal position. In the vertical position, the grips will be slightly stiffer, since there is no bending moment as there is in the horizontal position. However, it is slightly more difficult to load specimens with the grips in the vertical position. In the horizontal position (see Figures 3-3 and 3-4), specimen loading is easier, but there is more of a tendency for the grips to flex.

The grip faces are rubber coated to reduce specimen slippage in the grips, and are not interchangeable.

Chapter 2

Specifications

Overview

- Wedge Grips.....Page 2-2
- Screw Grips.....Page 2-4
- Chuck GripsPage 2-6
- Lever-Action Fiber Grips.....Page 2-8

This chapter gives electrical and physical specifications for the four types of grips covered in this manual.

Wedge Grips

Specifications

	1 kN grip	2 kN grip
Catalog Number	2716-016	2716-017
Max Capacity	1 kN (220 lb)	2 kN (440 lb)
Specimen Thickness	0.0 to 6.35 mm (0.0 to 0.25 in.)	0.0 to 6.35 mm (0.0 to 0.25 in.)
Jaw Face Width	19 mm (0.75 in.)	19 mm (0.75 in.)
Jaw Face Height	19 mm (0.75 in.)	19 mm (0.75 in.)
Operating Temp	0 to 100°C (32 to 212°F)	0 to 100°C (32 to 212°F)
Grip Mounting	Type O	Type O
Material	Anodized aluminum	Stainless steel

Dimensions

Overall Length (Jaws Extended)	94 mm (3.7 in.)
Overall Length (Jaws Retracted)	103 mm (4.0 in.)
Overall Width	54 mm (2.125 in.)

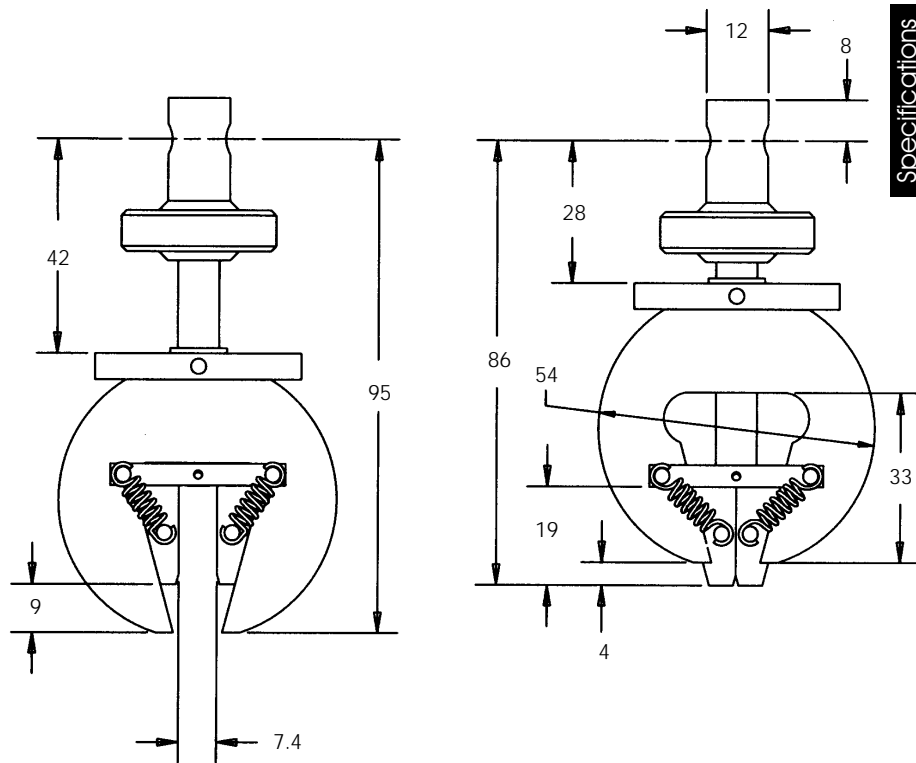

Figure 2-1. Wedge Grip Dimensions

Screw Grips

Specifications

Catalog Number	2710-004
Maximum Capacity	500 N (100 lb)
Maximum Specimen Size	12.7 mm (0.5 in.)
Jaw Face Size	25.4 x 25.4 mm (1 in. x 1 in.)
Operating Temperature	0 to 100°C (32 to 212°F)
Grip Mounting Type	Type "0", both ends

Dimensions

See Figure 2-2.

Overall Length	75 mm (2.95 in.)
Effective Length	67 mm (2.64 in.)
Overall Width	80 mm (3.15 in.) minimum 92.7 mm (3.65 in.) maximum
Screw Knob Diameter	23 mm (1 in.)
Weight	490 grams (1.1 lbs.)

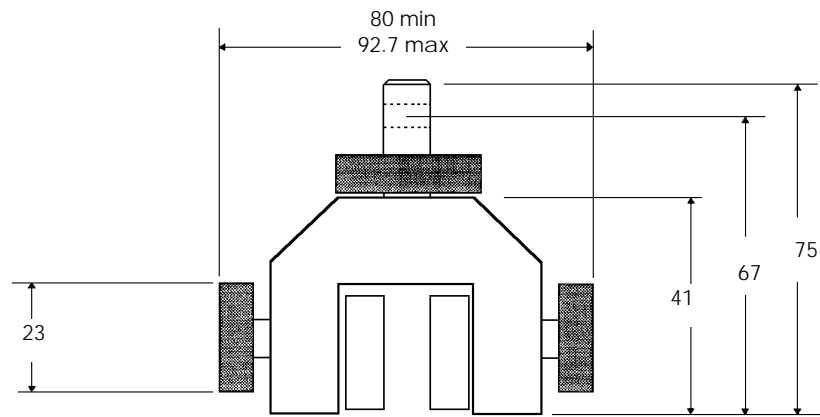

All Dimensions in Millimeters

Figure 2-2. Screw Grips Dimensions

Chuck Grips

Specifications

Catalog Number	2830-001
Maximum Capacity	500 N (100 lb)
Maximum Specimen Size	10 mm (0.395 in.)
Minimum Specimen Size	1.5 mm (0.06 in.)
Operating Temperature	0 to 100°C (32 to 212°F)
Grip Mounting Type	Type "0", both ends

Dimensions

See Figure 2-3.

Overall Length	90 mm (3.54 in.)
Effective Length	82 mm (3.23 in.)
Overall Diameter	45 mm (1.77 in.)
Weight	200 grams (0.44 lbs.)

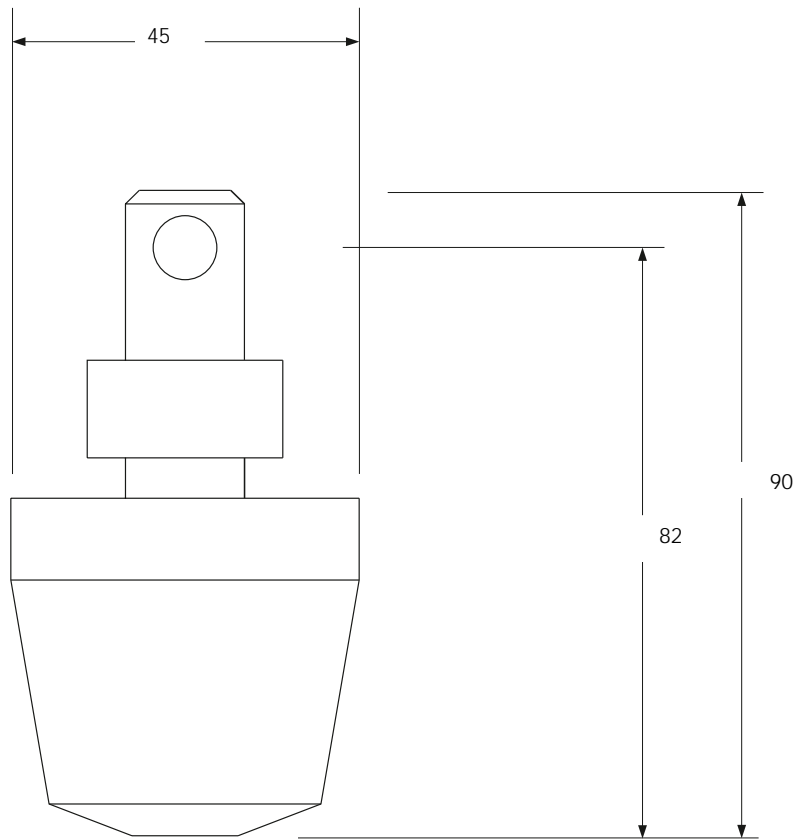

Specifications

All Dimensions in Millimeters

Figure 2-3. Chuck Grips Dimensions

Lever-Action Fiber Grips

Specifications

Catalog Number	2711-006
Maximum Capacity	500 grams (1.1 lb)
Maximum Specimen Size (O.D.)	2.5 mm (0.1 in.)
Operating Temperature	-200 to +250°F
Grip Mounting Type	Type "0", both ends

Dimensions

See Figure 2-4.	
Overall Length	111 mm (4.37 in.)
Effective Length	103 mm (4.05 in.)
Overall Width	
Vertical Orientation	25 mm (1.0 in.)
Horizontal Orientation	87.5 mm (3.45 in.)
Weight	38grams (0.085 lbs.)

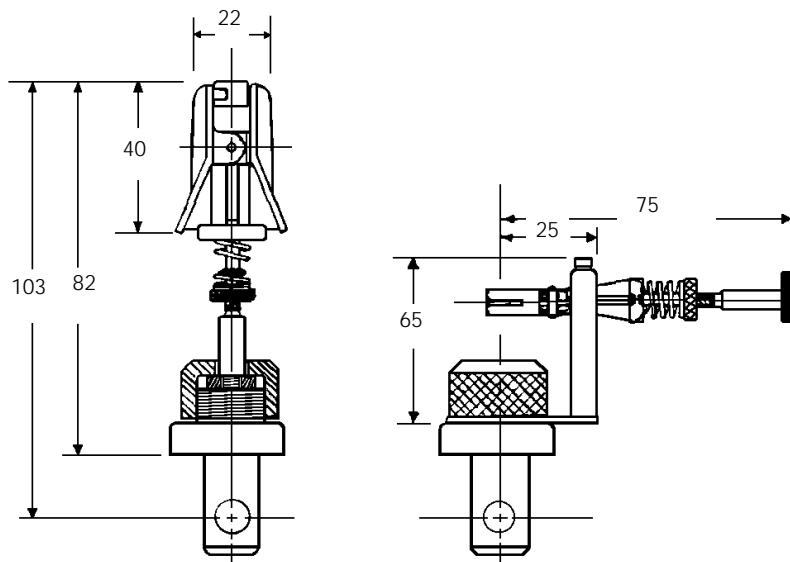

All Dimensions in Millimeters

Figure 2-4. Lever-Action Fiber Grips Dimensions

Chapter 3 Installation

Overview

- GeneralPage 3-2
- Grip InstallationPage 3-3
- Fiber GripsPage 3-5

This chapter contains installation instructions for the four types of Grips covered by this manual. It tells how to mount the grips in the load frame, and gives installation instructions specific to the type of grip.

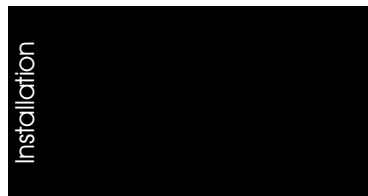

General

All of the grips covered in this manual have a grip attachment known as a Type 0 attachment. This attachment method uses a clevis arrangement that consists of a smooth stud and a mating socket, with a hole through both for a clevis pin. This type of attachment is used on both the load cell adapter and the baseplate adapter of the single column load frame.

Most of these grips also have a locking nut, sometimes called a checknut, that, when the grip stud is mated in its socket, is run up against the rim of the socket to eliminate any movement, or backlash, between the stud and socket.

Grip Installation

On the single column load frames, the load cell is usually mounted on the crosshead, and has a grip adapter mounted to it. A second, identical grip adapter is mounted on the frame base. Since both grips in each pair of grips are also identical, it makes no difference which grip is designated as the upper or lower grip.

For all grips covered by this manual, the following is the procedure for mounting the grips into the load frame:

Note *If you will be mounting the Fiber Grips in their horizontal position, go to the next section.*

- (a) Insert the clevis stud of one of the grips into the clevis socket in the upper grip adapter.
- (b) Align the horizontal holes in both the socket and stud, and insert a clevis pin through both.
- (c) Snap a locking clip onto the protruding ends of the clevis pin to keep the pin from falling out during testing.
- (d) If the grip has a locking ring, turn it until it contacts the rim of the clevis socket. While holding the grip with one hand, tighten the locking ring with the tommy bar (a straight, cylindrical rod) supplied with the grips, until the grips are locked into position. The tommy bar fits into holes in the rim of the locking ring.
- (e) Repeat steps (a) through (d) for the lower grip.

Fiber Grips

The Fiber Grips are normally used in a vertical, or axial, orientation. In this position, better specimen alignment can be obtained and the grips do not occupy as much of the test space. In this position, however, it is slightly more difficult to load specimens into the grips. Mounting the grips in the horizontal position will make it easier to load specimens, but there is somewhat more flex in the grips. The mounting positions of the two grips (upper and lower) do not need to match.

Converting from Vertical to Horizontal Mounting

To convert the Fiber Grips from a vertical to a horizontal mounting, do the following:

- (a) Unscrew the clamp nut (see Figure 3-1). This will separate the grip clamp assembly from the clevis adapter.
- (b) Slide the clamp nut down the grip shaft toward the grip clamps. This will expose the knurled clamp shaft nut. Remove the clamp shaft nut, then remove the grip assembly from the grip adapter.
- (c) Place the bracket assembly on the grip clevis adapter (see Figure 3-2), and tighten the clamp nut against it.
- (d) Back off the knurled adjustment nut on the grip frame to relieve the pressure on the grip faces. Remove both grip faces by pressing out the grip face pins.
- (e) Press the jaw face ends of the frames together. This provides enough clearance to pass the square post of

the bracket assembly between the jaw frames and the shaft.

- (f) Place the square portion of the shaft into the square cutout of the bracket mounting post. Leave approximately 1/32 in. clearance between the grip body and the post (see Figure 3-3). Tighten the clamping screw.
- (g) Replace the grip faces.
- (h) Replace the knurled clamp shaft nut removed in Step (b).
- (i) To convert the grips back to a vertical orientation, perform Steps (a) through (h) in reverse.

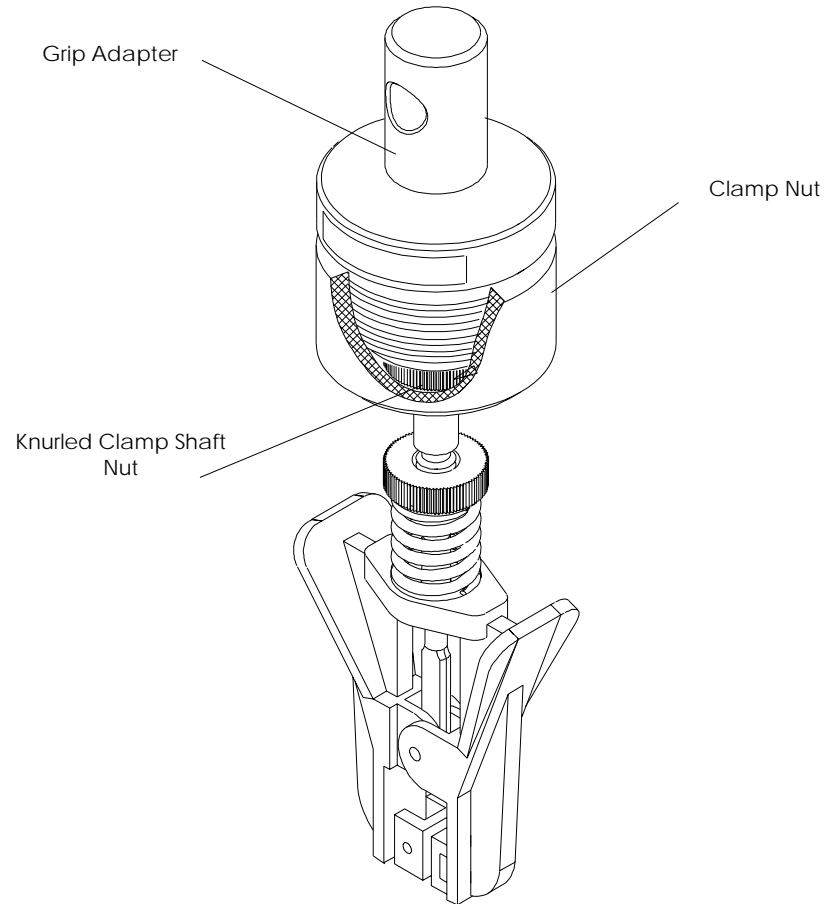
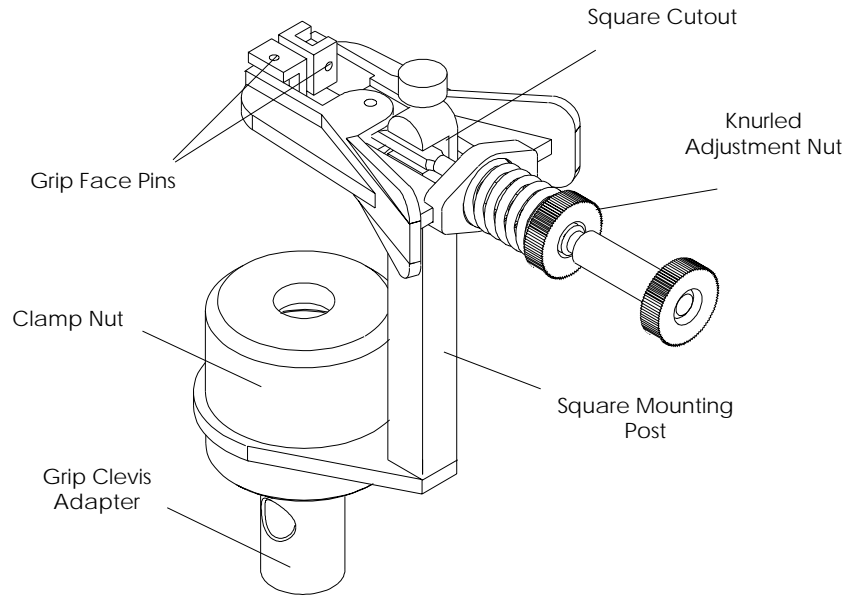

Figure 3-1. Vertical to Horizontal Mounting Conversion



Installation

Figure 3-2. Mounting the Grip

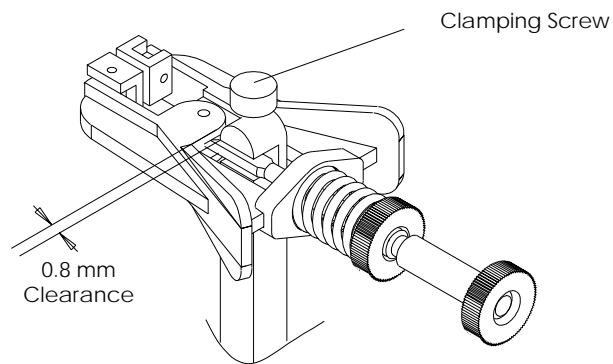

Figure 3-3. Adjusting Grip Position on the Post

Chapter 4

Operation

Overview

- General Page 4-2
- Wedge Grips Page 4-3
- Screw Grips Page 4-7
- Chuck Grips Page 4-11
- Lever Action Fiber Grips Page 4-13

This chapter gives operating instructions for the four types of Grips. It will tell you how to load specimens into the grips, and gives any operating instructions specific to the type of grip.

General

Operating instructions for the grips consist of instructions for loading specimens into the grips, making any adjustments necessary, and any instructions that are unique to the specific type of grip.

The following sections of this chapter describe these procedures in detail.

Wedge Grips

Operating the wedge grips consists of installing the proper grip faces for the type of specimen you are testing, and loading test specimens. The following sections describe these procedures.

Installing Grip Faces

The grip faces, Cat. No. 2703-171 for the wedge grips have diamond shaped 45° serrations. These are the standard faces for the wedge grips, and can handle flat specimens up to 6.35 mm (0.25 in.) in thickness.

To change the grips faces, do the following:

- (a) Begin to remove any grip faces currently installed in the grips by rotating the grip-actuating thumbwheel to open the grip faces.
- (b) Unhook the four springs from the pins on the grip faces (see Figure 4-1).
- (c) The grip faces are now loose in the body of the grip. Slide the faces out of the grip body.
- (d) Check that the grip body has a coating of lubricant on the interior surfaces that contact the grip faces. If necessary, renew with MolyKote™ G-N Paste grease, or equivalent. Do not allow excessive grease to get onto the new grip faces when they are installed. Wipe away excess grease.
- (d) Install the new grip faces by sliding a new pair of faces into the body of the grip.

- (e) While holding the grip faces in position, attach all four springs to the pins on the grip faces. Push the grip faces into position until they are seated in the track, if necessary, after attaching the springs.
- (f) Rotate the actuating thumbwheel throughout its range to make sure the grip faces are opening and closing properly.

Loading Specimens

To load specimens into the grips, do the following:

- (a) Open the upper grip, using the actuating thumbwheel, far enough to accommodate the thickness (or diameter) of the specimen.
- (b) While holding the specimen centered in the grip, rotate the thumbwheel to close the grip. Tighten the thumbwheel only enough to keep the specimen from falling out.
- (c) Open the lower grip using its thumbwheel.
- (d) Center the specimen in the lower grip (if the upper grip is not closed too tight, there will be some freedom of movement of the specimen).
- (e) Close the lower grip by tightening its thumbwheel.
- (f) Check the specimen alignment (it should be centered in the grips and in line with the longitudinal axis of the grips). Adjust the specimen position if necessary.
- (g) Tighten both grips firmly by holding the grip with one hand while turning the thumbwheel with the other. The grips should be tightened enough to provide firm gripping pressure on the specimen, but

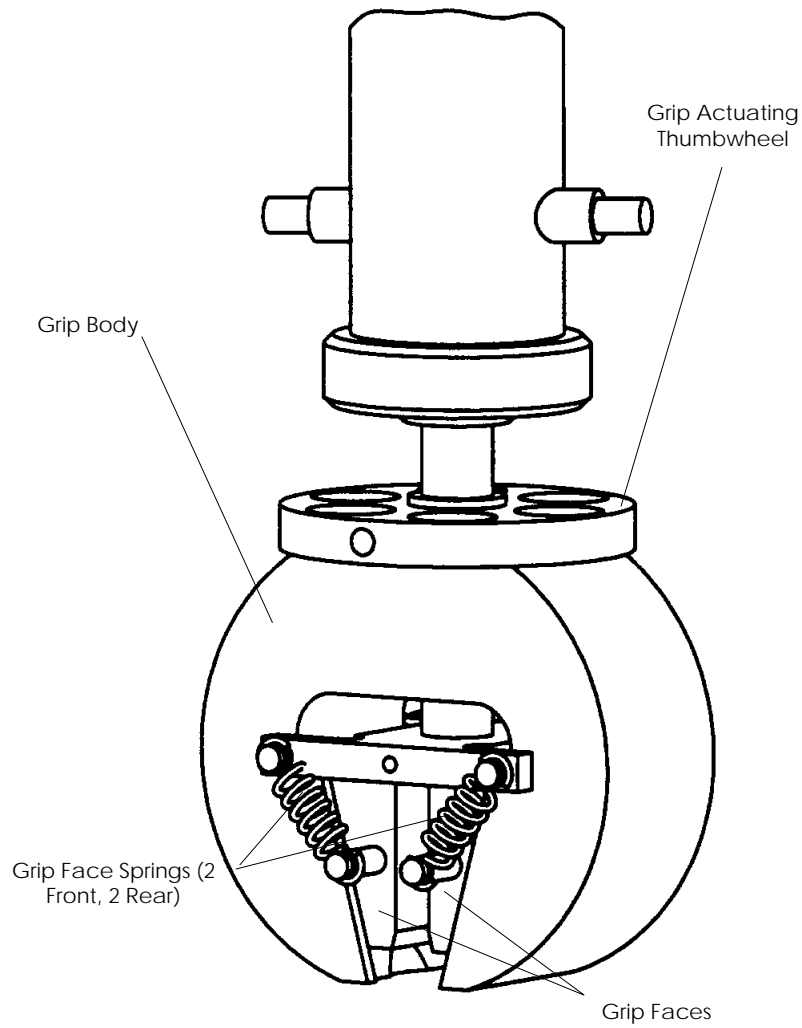

Operation

Figure 4-1. Wedge Grip Operation

keep in mind that gripping pressure will tend to increase with increasing test tension on the specimen.

Screw Grips

Operation of the screw grips consists of installing the proper grip faces for the type of specimen you will be testing, and loading test specimens. The following sections describe these procedures.

Installing Grip Faces

There are four types of grip faces available for the Screw Grips, which are attached by means of set screws. The four types are described as follows:

- Smooth Face, Cat. No. 2702-130 - These faces work with a wide variety of specimens, and are the standard grip faces for the Screw Grips.
- Serrated Face, Cat. No. 2702-131 - These faces have a diamond pattern, 40-teeth per inch serration, and are used for hard or metallic specimens that are more difficult to grip than standard specimens.
- Rubber Face, Cat No. 2702-132 - These faces have a thin rubber surface bonded to the faces to grip thin specimens such as paper and polymer films that cannot be gripped satisfactorily with the above faces.
- Line Contact Face, Cat. No. 2702-133 - These faces have a rubber surface bonded to one face, and have a horizontal, semi-circular rib molded into the other face. These faces are generally used for soft specimens.

It is not necessary to have the same type of grip faces in both the upper and lower grips. It is necessary, however,

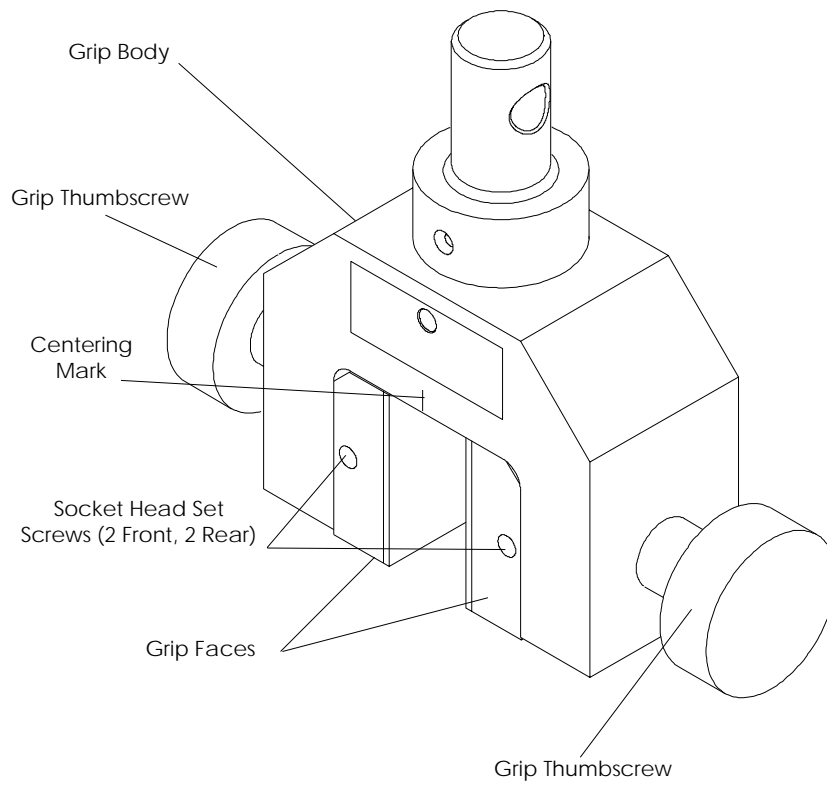

Figure 4-2. Screw Grip Operation

to have a pair of faces of the same type in each individual grip.

To install these faces in the Screw Grips, perform the following:

- (a) Select a type of grip face compatible with the type of specimen you will be testing.
- (b) If other grip faces are already installed in the grips, remove them by loosening the two socket head set screws in the sides of each grip face (four screws, in all), using the 1.5 mm hex wrench supplied with the grips. See Figure 4-2.
- (c) Slide the grip faces out of the grips.
- (d) Position each of the new grip faces in the body of the grip over the end of the screw shaft. Tighten the socket head set screws while holding the face in place, using the 1.5 mm hex wrench. There should be a small amount of movement of the grip faces when the set screws are tightened properly.

Loading Specimens

To load specimens into the grips, do the following:

- (a) Open both upper and lower grips by unscrewing both thumbscrews on each grip.
- (b) While holding the specimen in place in the upper grip, tighten both thumbscrews of the upper grip enough to hold the specimen. Ensure the specimen is centered forward-to-back in the grip. Do not fully tighten the thumbscrews at this time.

- (c) Position the specimen in the lower grip so that it is in line with the upper grip, and then tighten the thumbscrews. Again, do not fully tighten yet.
- (d) On the upper grip, adjust the thumbscrews in or out in tandem to align the specimen with the centering mark above the opening on the body of the grip.
- (e) Repeat Step (d) for the lower grip.
- (f) Without upsetting the adjustment in the previous two steps, tighten the two thumbscrews simultaneously on each of the upper and lower grips enough to provide the required gripping force for the test.

Chuck Grips

The chuck grips are lightweight three-jaw keyless chucks of a type used in electric drills. The jaws have a soft plastic coating for easy tightening. The gripping force on the specimen can be adjusted by varying the amount of twist when tightening the grips. The grip jaws are not removable.

Operation of the grips is simply a matter of loading specimens into the grips, as follows:

- (a) While holding the grip coupling with one hand, rotate the grip collar to open the grip jaws on both the upper and lower grips.
- (b) Raise the crosshead of the load frame enough to be able to insert a specimen into both upper and lower grips.

Note

Tightening the grip collar retracts the grip jaws into the body of the grip, which may place an undesirable tensile load on the specimen. If this is the case, use load control on the testing system control panel, and monitor the load as the grip collars are tightened. Reduce the load on the specimen as necessary.

- (c) Insert a specimen into the upper grip and tighten the collar enough to hold the specimen in place. Do not tighten the collar completely.
- (d) Lower the crosshead while guiding the lower end of the specimen into the lower grip.
- (e) Tighten the collar on the lower grip enough to provide the necessary gripping force on the specimen.

Hold the grip adapter with one hand while tightening the collar with the other hand to prevent twisting the load string.

- (f) Tighten the collar on the upper grip enough to provide the necessary gripping force, as in Step (e).

Lever-Action Fiber Grips

The lever-action fiber grips have two spring-loaded levers that press the grip faces together. Squeezing the levers opens the grips to allow a specimen to be inserted. When the levers are released, spring tension closes the jaws on the specimen, and the spring tension is adjustable. The grip faces are not removable.

Loading Specimens

Loading specimens into the grips is the same for both horizontal and vertical orientations of the grips. To load specimens into the grips, do the following:

- (a) Squeeze the levers of the upper grip with one hand while placing the fiber specimen in the jaws with the other.
- (b) Release the levers when the specimen is centered in the grip.
- (c) Repeat Steps (a) and (b) for the lower grip. Make sure the fiber specimen is taut between the two grips.

Adjusting Gripping Force

Adjusting gripping force on the specimen will require a certain amount of trial and error to find a spring tension that will prevent the fiber specimen from slipping in the grips, but will not crush the specimen. If specimen crushing is not likely to be a problem, then just adjust the spring tension as high as you wish. To adjust gripping force, do the following:

- (a) Load a fiber specimen into the grips.

- (b) Perform a dummy test on this specimen to see if the specimen slips in the grips. This test should approximate the actual test conditions that will be performed on similar specimens.
- (c) If the specimen is slipping in the grips, increase the gripping force by rotating the adjusting nut, adjacent to the spring, clockwise by one or two full turns (see Figure 4-3).
- (d) Run the dummy test again and check for specimen slippage.

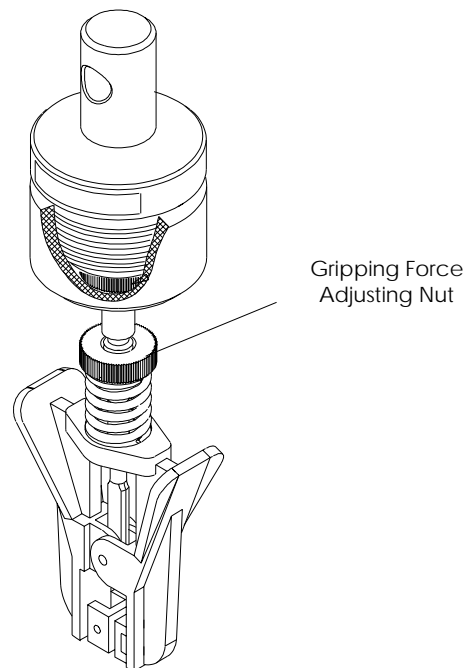

Figure 4-3. *Lever Action Fiber Grips Operation*

- (e) It may take several tries of adjusting the spring tension and running the test in order to eliminate specimen slippage. Again, if you are not concerned about specimen crushing, simply adjust the spring tension for a high gripping force.

Chapter 5

Maintenance

Overview

- GeneralPage 5-2
- Lubricating Wedge GripsPage 5-3

This chapter gives some routine maintenance procedures for keeping your grips in top operating condition. Included are general instructions for cleaning and lubrication.

General

Maintenance of the four types of grips consists mainly of keeping the moving parts free of dirt and grit. Since most of the grips have some plastic parts, do not use solvents or harsh cleaners to clean them.

The wedge grips are the only grips that require lubrication. Refer to the next section for lubrication instructions.

Lubricating Wedge Grips

You must lubricate the jaw faces in the wedge grips in order for the grips to operate smoothly and freely. You should lubricate the jaw faces whenever:

- Grip faces are changed.
- Grip operation becomes rough or erratic.
- The grease on the backs of the jaw faces becomes hard or caked.
- Excessive dirt and debris have been picked up in the grease.

To lubricate the jaw faces, do the following:

- (a) Remove the grip faces from the body of the grips (see Chapter 4). It is not necessary to remove the grips from the load frame, but removal may make the work easier.
- (b) Using a mild solvent, remove old grease from the back sides of the grip faces and the interior of the body of the grips.
- (c) Using Molykote™ G-N Paste grease, coat the grip face tracks inside the body with grease. Do not use excessive amounts of grease, and keep it away from the gripping face of the jaw faces. A tube of this grease is supplied with the grips.
- (d) Reinstall the grip faces in the grip bodies (refer to Chapter 4).

Chapter 6

Illustrated Parts

Overview

- GeneralPage 6-2
- Wedge Grips Parts ListPage 6-4
- Screw Grips Parts ListPage 6-6
- Chuck Grips Parts ListPage 6-8
- Lever Action Fiber GripsPage 6-10

This chapter gives replaceable parts information for the four types of grips covered by this manual. The parts list shows the location and identification of parts.

General

To use the information in this chapter for parts identification, first locate the part on an illustration, note its item number, and then refer to this item number in the associated parts list.

Please note the following:

- Generally, a subassembly that is normally supplied and replaced as an assembly is not broken down into its component parts.
- The DESCRIPTION column lists the common name for the item, and may give the manufacturer's part number when appropriate. These parts will have both a manufacturer's part number and an Instron part number.
- The PART NO. column lists the Instron part number only.
- The quantity listed in the QTY. column is for one grip only. To obtain quantities for a set of grips (two grips), multiply the quantity shown by 2.

When ordering parts from Instron, be sure to include the catalog number of your grips, as described in Chapter 2 of this manual. This information will help Instron's Customer Support Center to determine the correct part for your system.

Wedge Grips Parts List

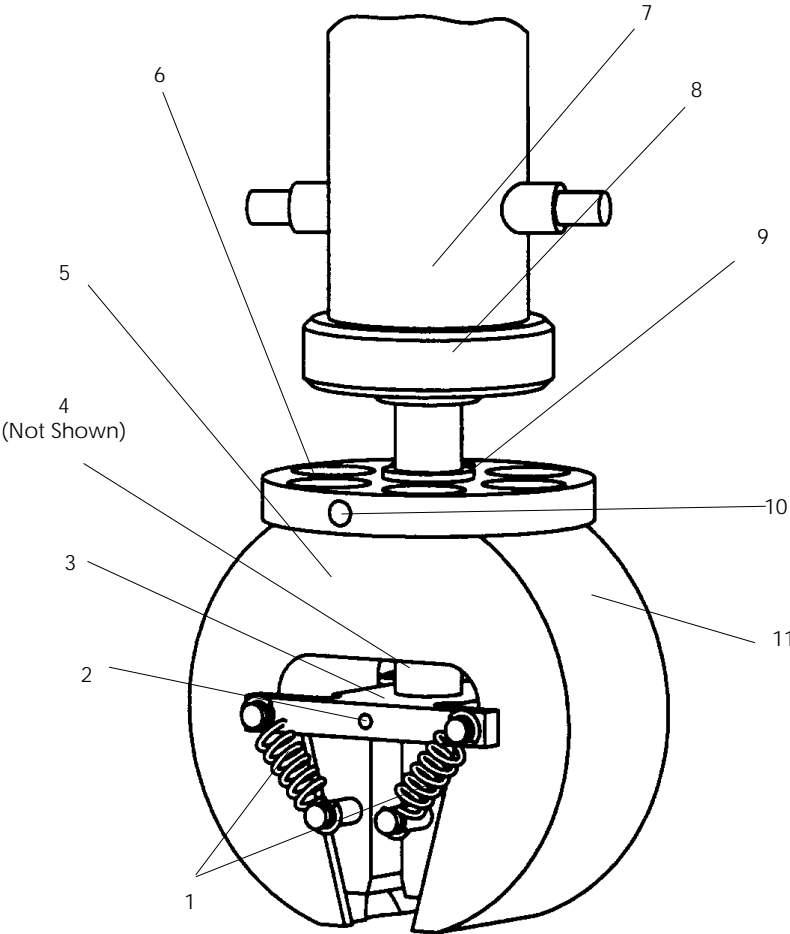

Figure 6-1. Wedge Grips Parts Breakdown

Refer to Figure 6-1

Table 6-1. Wedge Grips Parts List

Item No.	Description	Part No.	Qty.
1	Jaw Face Spring	66-1-1084	4
2	Retaining Pin, 0.62 x 0.75 in.	703D11	1
3	Jaw Actuating Plate	A563-432	1
4	Body Nut	T563-624	1
5	Label	T563-623	1
6	Thumbwheel	T563-620	1
7	Spindle	T563-631	1
8	Locknut	T1223-1018	1
9	Wave Spring Washer	66-10-21	1
10	Socket Head Set Screw, M3 x 6	401F93	1
11	Body, Wedge Grip	T563-619 (1 kN)	1
		T563-338 (2 kN)	1
ACCESSORIES			
–	Tommy Bar	106-2-4	1

Screw Grips Parts List

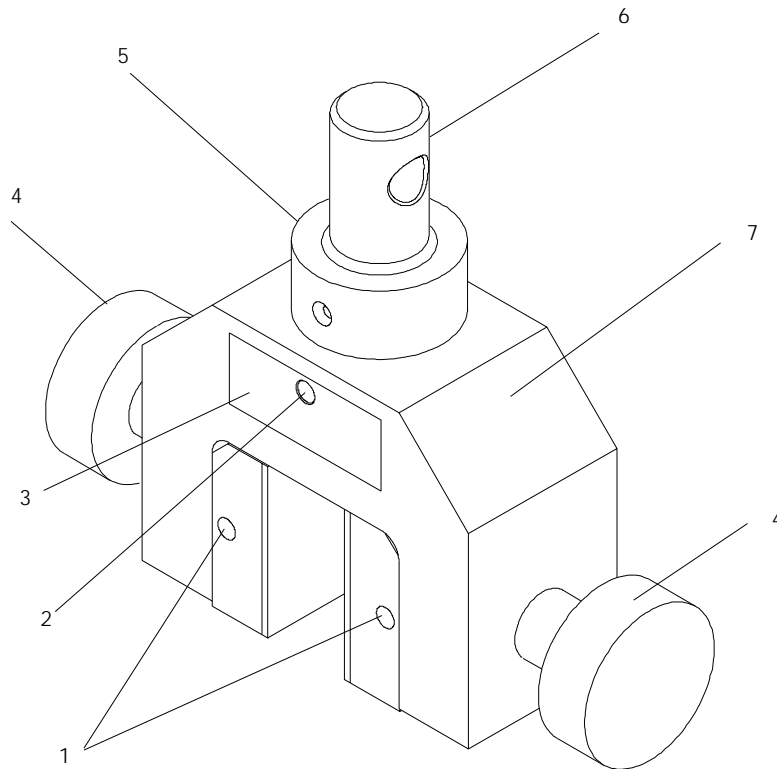

Figure 6-2. Screw Grips Parts Breakdown

Refer to Figure 6-2

Table 6-2. Screw Grips Parts List

Item No.	Description	Part No.	Qty.
1	Socket Head Set Screw, M3 x 10	401E95	4
2	Roll Pin, 3 x 24 mm	703F051	1
3	Label	T563-366	1
4	Knurled Knob and Screw	T563-327	2
5	Locknut	T1223-1018	1
6	Grip Adapter, Type "0"	T563-325	1
7	Body, Screw Grip	T563-324	1
	ACCESSORIES		
–	Tommy Bar	106-2-4	1
–	Hex Wrench, Short Arm, 1.5mm	206D4	1

Chuck Grips Parts List

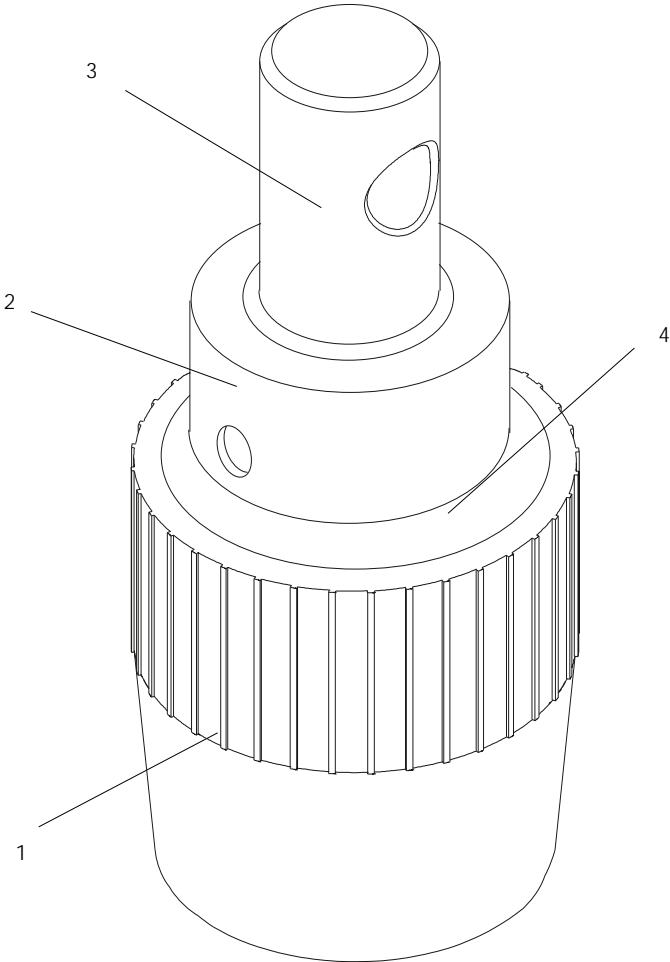

Figure 6-3. Chuck Grips Parts Breakdown

Refer to Figure 6-3

Table 6-3. Chuck Grips Parts List

Item No.	Description	Part No.	Qty.
1	Tool Chuck, 1.5 to 10 mm, Keyless	80-54-1027	1
2	Lock Nut	T1223-1018	1
3	Grip Adapter, 3/8-24 to Type "0"	T563-377	1
4	Label	T563-373	1
	ACCESSORIES		
–	Tommy Bar	106-2-4	1

Lever Action Fiber Grips Parts List

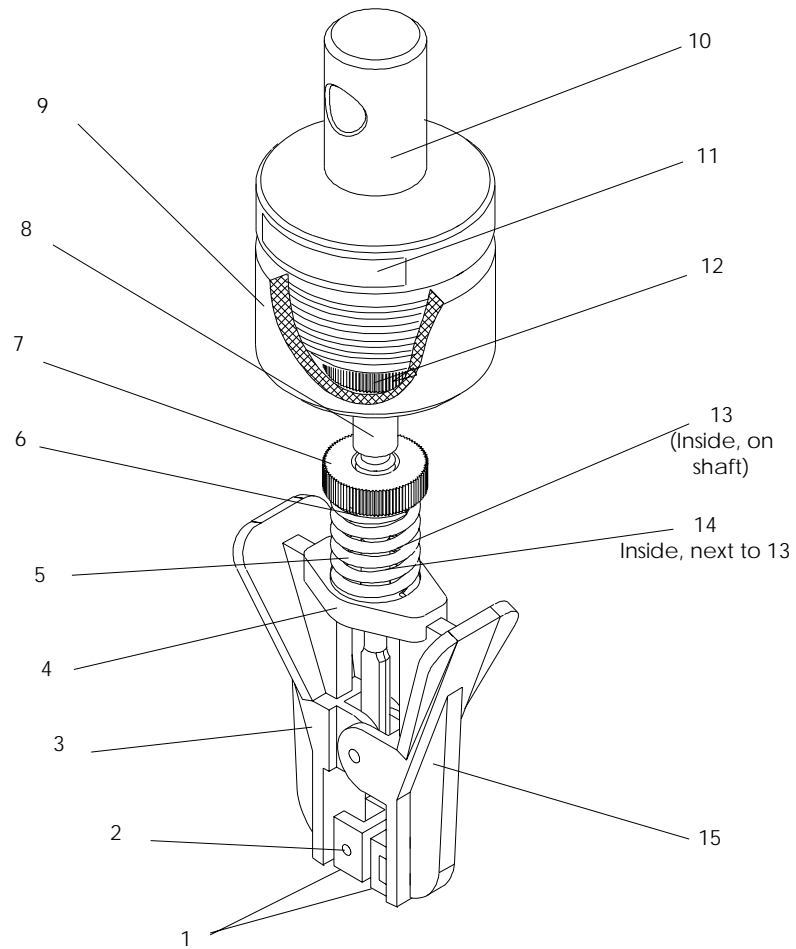

Figure 6-4. Lever Action Fiber Grips Parts Breakdown

Lever Action Fiber Grips Parts List

Refer to Figure 6-4

Table 6-4. Lever Action Fiber Grips Parts List

Item No.	Description	Part No.	Qty.
1	Jaw Face Assembly	A2-189	2
2	Jaw Face Pin	T2-352	2
3	Grip Frame, Right	T2-761	1
4	Wedge Collar	T2-339	1
5	Compression Spring, 3/8 OD	66-3-5	1
6	Spring Washer	T2-348	1
7	Adjustment Nut	T2-349	1
8	Central Shaft	T2-374	1
9	Grip Nut	T2-375	1
10	Grip Adapter, Type "0"	T563-316	1
11	Label	T563-361	1
12	Shaft Nut	T2-376	1
13	Truarc Ring, #5133-12	60-6-5	1
14	Compression Washer	T2-523	1
15	Grip Frame, Left	T2-762	1

Illustrated Parts

Item No.	Description	Part No.	Qty.
	Horizontal Mounting Parts <i>consisting of:</i>		
16	Clamp Screw	T2-377	1
17	Lower Clamp Bracket Assembly	A2-162	

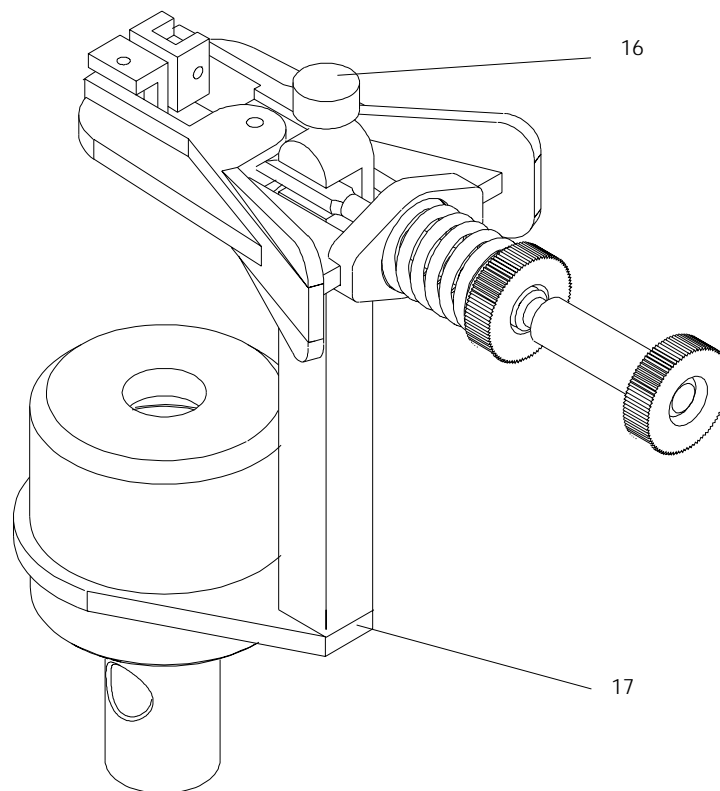

Figure 6-5. Horizontal Mounting Parts